

# EXTEND-A-RAIL

FACTORY FINISH  
ALUMINUM - ANODIZED

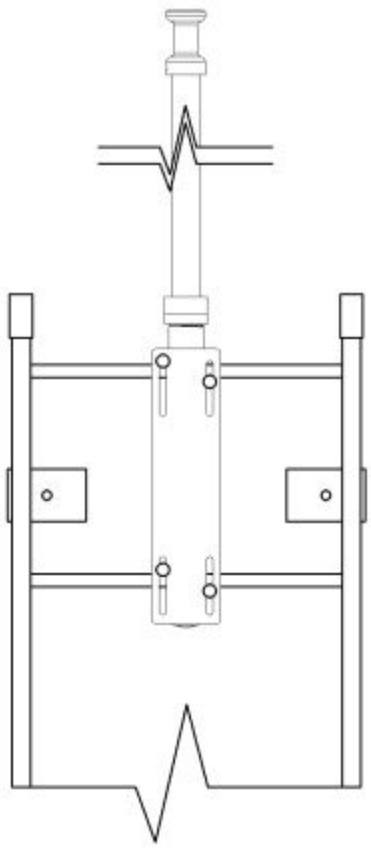

NOTE:  
PLACE BOLTS IN CONFIGURATION SHOWN  
FOR REQUIRED APPLICATION.  
(BOLTS, NUTS AND WASHERS INCLUDED)

MODEL: ER-1  
EXTEND-A-RAIL LADDER SAFETY POST  
SHIPS COMPLETELY ASSEMBLED

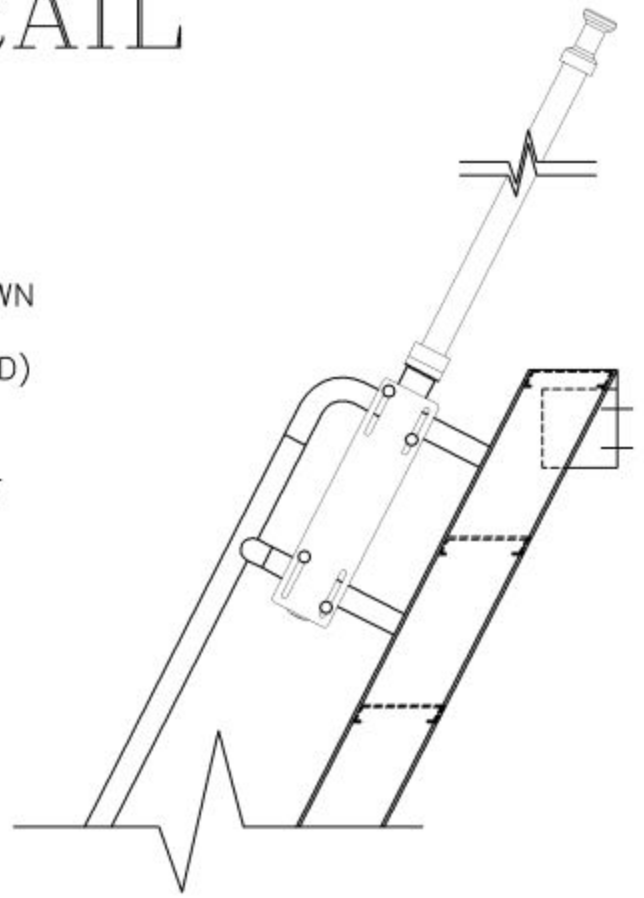

NOTE: RETRO-FIT SHIPS LADDER  
INSTALLATIONS REQUIRE CUSTOM  
BRACKET NOT SHOWN.

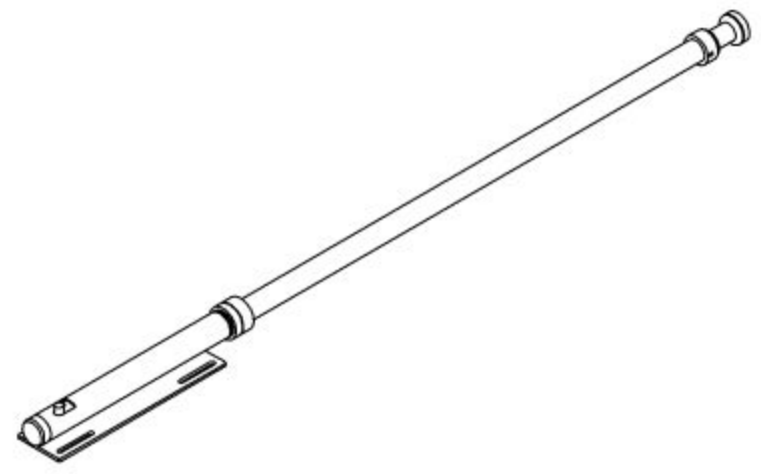

69-1/4"

LENGTH ABOVE TOP  
TREAD IN DOWN POSITION

7-1/2"

16"

ER-1

NOT TO SCALE

 <b>Precision Ladders, LLC</b> P.O. BOX 2279 Morristown, TN 37816-2279 Ph: (423) 586-2265 Fax: (423) 586-2091 www.PrecisionLadders.com	DWG. CHECK WORK ORDER: ( )	ARCHT OR ENGR. PURCHASE ORDER	PROJECT WORK ORDER		PRECISION REP SERIAL#
	BUILT BY:	DRAWN BY: DNH	PURCHASER	DATE 3/9/16	MODEL# ER-1
	CHECKED BY:	QTY.			